

REMOTE HOSE KIT

ASSEMBLY INSTRUCTIONS

1. Attach handle to front hole in nozzle tube. using a hex bolt 5/8" long (Ref. 2) and hex lock nut (Ref. 3). Do not tighten at this time.
2. Place bowed washer (Ref. 8) onto a 1-1/2" long hex bolt (Ref. 1), and place hex bolt (with washer attached) down through the rear hole in the handle and nozzle tube. Secure with hex lock nut (Ref. 3). Tighten both hex bolts and nuts securely.
4. Slide a hose clamp (Ref. 5) onto one end of the hose (Ref. 10), loosening the clamp if necessary. Slide the end of the hose over the round end of the nozzle tube, and secure with the hose clamp.
5. Slide the other end of the hose approximately 1-3/4" into the hose adapter so that the four holes in the neck of the adapter align between the hose's ribs.
6. Drill one 1/4" hole between the ribs of the hose. Place a flat washer (Ref. 13) onto a 1" long hex bolt (Ref. 12). Insert the bolt through the hose and adapter from the inside. Assemble a flat washer (Ref. 12) and hex lock nut (Ref. 13) onto the bolt on the outside of the adapter
7. Drill three more holes and assemble fasteners in the same manner.
8. Remove the Vac's hose adapter by removing the three nuts. Place the kit's hose adapter onto the weld studs, and secure with the three nuts just removed.



WARNING: Be certain to stop the engine and disconnect the spark plug wire from the spark plug before attaching or removing the hose kit from the Vac.

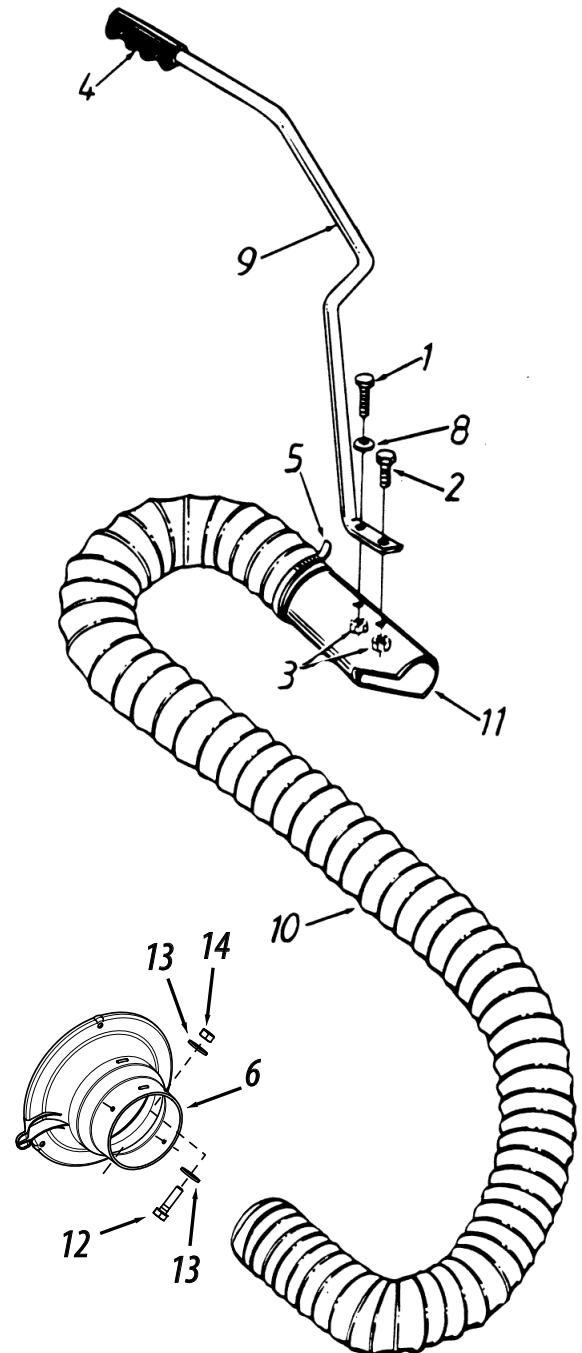

PARTS LIST

REF. NO.	PART NO.	QTY.	DESCRIPTION
1	43648	1	Hex Bolt, 1/4-20 x 1-1/2" Lg.
2	43866	1	Hex Bolt, 1/4-20 x 5/8" Lg.
3	47189	2	Nylock Nut, 1/4-20 Thd.
4	46471	1	Grip
5	43793	1	Adj. Hose Clamp 6" Dia.
6	27720	1	Hose Adapter
8	44695	1	Bowed Washer, .32" I.D.
9	749-0005BL3	1	Handle
10	41883	1	Hose, 5" Dia.
11	731-01524	1	Nozzle Tube
12	43661	4	Hex Bolt, 1/4-20 x 1" Lg.
13	42977	8	Flat Washer, .28 I.D.
14	43013	4	Hex Lock Nut, 1/4-20 Thd.

REPAIR PARTS

811 South Hamilton
Sullivan, IL. 61951
217-728-8388